

Evaporative Air Cooler FL-1701R



INSTRUCTIONS FOR INDOOR HOUSEHOLD USE ONLY.

IMPORTANT SAFETY INFORMATION

READ AND FOLLOW ALL INSTRUCTIONS BEFORE OPERATING. DO NOT USE IF ANY PART ARE DAMAGED OR MISSING.

Read and follow all of the instructions even if you feel you are familiar with the product, and find a place to keep this manual handy for future reference.

Important: This appliance is intended for use in a domestic environment only. Any other use is not recommended by the manufacturer and may cause fire, electrical shocks or other injury to user or property. When using electrical appliances, basic safety precautions should always be followed:

REMOTE CONTROL



WARNING! Keep batteries out of reach of children. Swallowing may lead to serious injury or death in as little as 2 hours due to internal burns. If swallowed, go straight to a hospital emergency room. Dispose of used batteries immediately.

- The remote control uses 1 x CR2025 button cell battery (included). Please remove the plastic tab before first use.
- The remote control buttons have the same functions as that of the control panel.



Opening the battery compartment

- Lay the remote control face-down on a table and hold it down with your left hand.
- Insert the thumbnail of your right hand into the release tab, and your index fingernail into the pull-groove.
- With your thumbnail, squeeze the release tab inwards whilst at the same time sliding the battery holder out with your index fingernail.

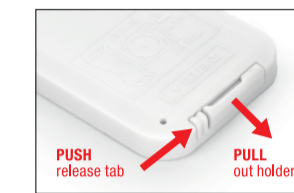

CLEANING AND MAINTENANCE

CAUTION!

- Always switch off and unplug the unit before removing the filters or performing any cleaning.
- Do not use harsh detergents, chemical cleaners or solvents as they may damage the surface finish of the plastic components.

MAIN BODY

- Use a soft duster or a rag to dust off all the surfaces.
- Clean the air inlet and air outlet using a vacuum cleaner regularly.
- Wipe all the parts with a soft damp (not wet) cloth dipped in mild soapy water. **CAUTION!** Ensure that water does not get inside the unit.
- Use a dry cloth to thoroughly dry the unit before turning on.

OVERVIEW

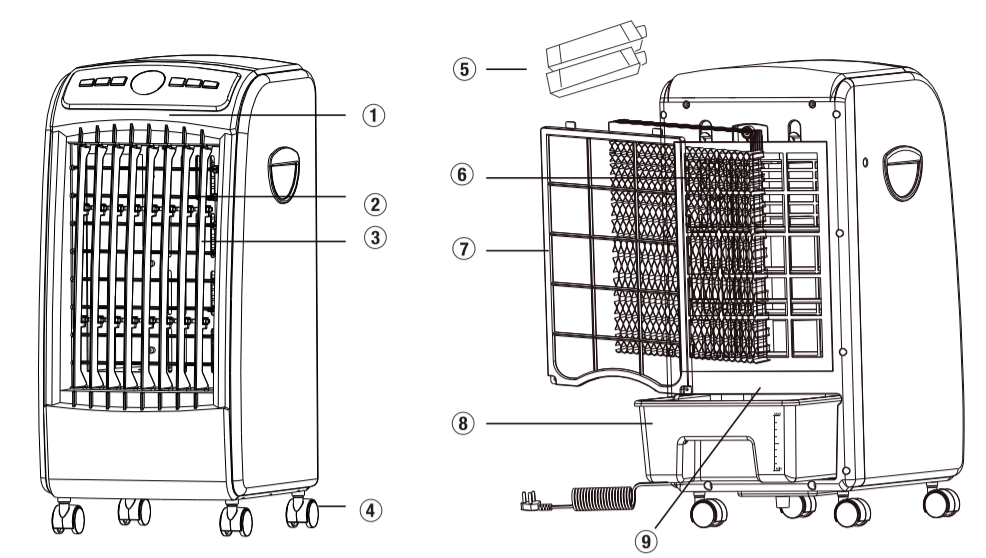

- | | | |
|------------------------|------------------|--------------------|
| 1. Control Panel | 4. Caster Wheels | 7. Air Inlet Cover |
| 2. Oscillating Louvres | 5. Ice Blocks | 8. Water Tank |
| 3. Horizontal Louvres | 6. Filter | 9. Water Tank Lock |

Note: The ice blocks are supplied empty; add water and freeze for a few hours before use.

ASSEMBLY

Note: The 4 x caster wheels must be installed before using this cooler.

- Spread a soft cloth or mat on a level floor. Carefully place the unit upside down on the soft cloth or mat.
- Insert each caster wheel fully into the 4 x holes on the bottom of the unit.

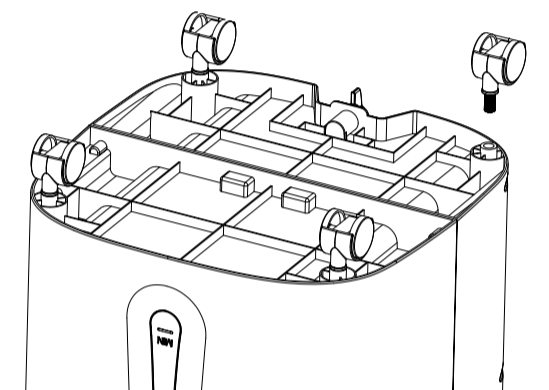

Safety Information

Important - Please read these instructions fully before assembly or use

OWNER'S MANUAL

Please read carefully and keep for future reference.

WARNING

Important Safety Information

When using electrical appliances, basic safety precautions should be followed to reduce the risk of fire, electric shock and personal injury.

- Use this cooler only as described in this manual. Other use not recommended may cause fire, electric shock or injury to persons. This will also void your warranty.
- Always operate the product from a power source of the same voltage, frequency and rating as indicated on the rating label.
- This product is intended for indoor, household use ONLY. Do not use outdoors or for commercial or industrial purposes.
- To protect against electric shock: do not immerse unit, plug or cord in water or spray with liquids; do not place unit on windowsills or other places where it may be exposed to dripping or splashing of water; do not place vases or similar objects filled with liquids near the unit.
- Do not use this product in the immediate vicinity of water, such as bathtubs, wash bowls, swimming pools etc. where the likelihood of immersion or splashing could occur.
- To reduce the risk of fire or electric shock, do not use this product with any solid-state speed control device.
- This appliance is not intended for use by persons (including children) with reduced physical, sensory or mental capabilities, or lack of experience and knowledge, unless they have been given supervision or instruction concerning use of the appliance by a person responsible for their safety.
- This product is not a toy! Children should be supervised to ensure that they do not play with the appliance.
- Turn the unit OFF and unplug it from the outlet when not in use, when moving the unit from one location to another and before disassembling or cleaning. Fully assemble the unit before switching on again.
- To disconnect the unit, first turn it OFF, grip the plug and pull it from the wall outlet. Never pull the plug by the cord.
- Do not operate the cooler in the presence of explosive and/or flammable fumes.
- Do not place the product or any parts near an open flame, cooking or other heating appliance.
- Do not operate product with a damaged cord or plug, or if the product malfunctions, or is dropped or damaged in any manner.
- Avoid contact with moving parts. Do not insert any body parts (e.g. finger) or objects through the grill when the unit is operating.
- The use of attachments not recommended by the manufacturer may be hazardous.
- Place the unit on a dry level surface to avoid overturning.
- Do not operate if the product housing is damaged.
- Do not cover the grill, or operate in close proximity to curtains, etc. Ensure adequate ventilation around the unit.
- A loose fit between the AC outlet (receptacle) and plug may cause overheating and a distortion of the plug. Contact a qualified technician to replace loose or worn outlet.
- If the supply cord is damaged, it must be replaced by the manufacturer, its service agent or similarly qualified persons in order to avoid hazard.
- If the product is not working properly, contact a qualified technician for examination and repair. Never attempt to dismantle the unit yourself.
- Never install or store the unit where it could be subject to:
 - Heat sources such as radiators, heat registers, stoves or other products that produce heat
 - Direct sunlight
 - Mechanical vibration or shock
 - Excessive dust
 - Lack of ventilation, such as a cabinet or bookcase
 - Uneven surfaces
- Do not leave the product running unattended.
- The castor wheels must be attached before use.
- Do not remove the water tank while the unit is plugged in.

AIR INLET AND INNER FILTER

- Use a screwdriver to unscrew the two cover screws.
- Remove the air inlet cover and wipe clean, or clean using a vacuum cleaner.
- Use a duster to gently dust off the inner filter.
- Replace the inner filter and air inlet cover and tighten the screws to fix it in position.

WATER TANK

WARNING! Unplug the unit from the mains supply before removing the water tank. (see page 4 for instructions)

- When the unit or the cool function will not be used for some time, empty the water from the water tank.

- Use mild soap and water to clean the water tank.

- Allow it to air dry or wipe dry using a soft cloth. Make sure the water tank is completely dry before replacing. This helps prevent any mould or mildew inside the water tank.

- Empty the water and dry out the ice blocks before storage.

Make sure the air inlet cover and water tank are replaced in position before switching on again.

TECHNICAL SPECIFICATIONS

Rated Voltage: 110V~ 60Hz Product Size: 240 x 250 x 540mm
Rated Power: 65W Tank Capacity: 4 Litres

Note: As a result of continual improvements, the design and specifications of the product within may differ slightly from the unit illustrated on the packaging.

STORAGE AND DISPOSAL

If you do not plan to use the product for extended periods of time, it is recommended that it is cleaned and stored (preferably in its original packaging) in a cool, dry place.

Do not put your batteries in with your household rubbish. Take them to an appropriate disposal/collection site.

Do not dispose of electrical products with household waste. Please check with your local council for advice on disposal or recycling. If electrical appliances are disposed of in landfills or dumps, hazardous substances can leak into the groundwater and get into the food chain, damaging your health and well-being.



MADE IN CHINA

USING THE ICE BLOCKS (OPTIONAL)

There are two ice blocks included that can be used for extra cooling effect, if desired.

IMPORTANT!

- Use only clean water for filling the ice blocks. Do not fill water above the maximum marking.
- The ice blocks are not food safe, do not use for storing food or beverages.
- Keep away from children.
- Empty the water and dry out the ice blocks before storage.

- Open the cap, add clean water up to the maximum level marking, close and place in your freezer for a few hours.
 - Once frozen, the ice blocks can be added to the water tank.
- Note:** Make sure that the water level in the tank does not go above the 'MAX' level indicated.

OPERATION

WARNING!

- Make sure that the caster wheels are attached before switching the unit on.
- Once the water is filled, take extra care to ensure that you don't tilt the unit.
- Push the unit gently if you wish to move it to a new position.
- Do not remove the water tank while the unit is plugged in.

- Keep the unit on a flat, stable ground without any obstacles near it.

- Connect the power plug to a suitable electrical outlet with the same specifications as mentioned in the unit's rating label (see technical specifications for details). When the supply is turned on at the outlet, the unit receives power and is in standby mode. The power indicator light turns on.

- You may now use the control panel buttons or the remote control to operate the cooler.

CONTROL PANEL

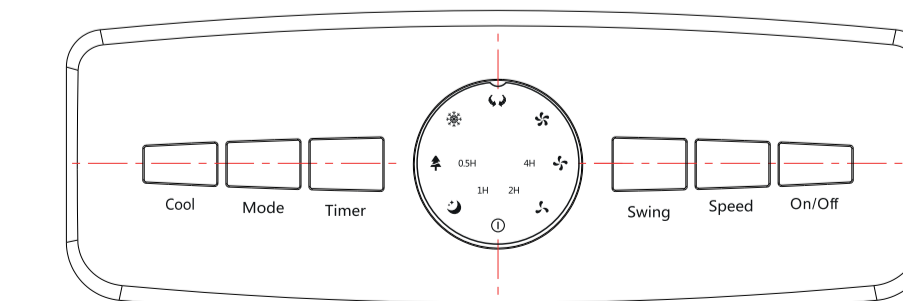

ON/OFF-STANDBY

- Press the ON/STANDBY button to turn on the unit. The unit starts working in medium speed and switches to low speed after 3 seconds.
- When the unit is working, press the ON/STANDBY button again to switch it back to standby mode.

SPEED

- Press the speed button to adjust the speed. There are three positions - Low, Medium or High. The corresponding indicator turns on.

SWING

- Press this button to start or stop louvre oscillation from left to right. The corresponding indicator turns on.

TIMER

- Press this button to set the turn-off time for the unit.
- The turn-off time can be set in half-hour increments from 0.5 to 7.5 hours. There are 4 indicators - 0.5H, 1H, 2H and 4H. For example, if the timer is set for 3 hours, the 1H and 2H indicators turn on.

MODE

There are three selectable modes, the corresponding indicator turns on.

Normal Mode: The fan operates in the constant speed set using the SPEED button.

Natural Mode: The unit simulates a natural breeze..

Sleep Mode: The unit simulates a gentle breeze suitable for night-time use.

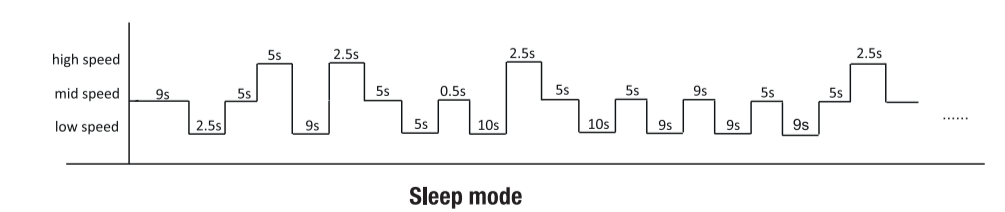
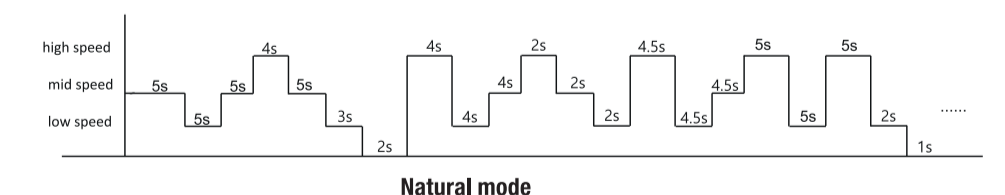

COOL

- Press this button for a cool breeze when water is added to the water tank. The corresponding indicator turns on.
- Press again to turn off the cool breeze.