

ITEM NAME: HDPE Adirondack Chair
 ITEM NO.:FYSW31

IMPORTANT NOTE: DO NOT OVERTIGHTEN THE BOLTS

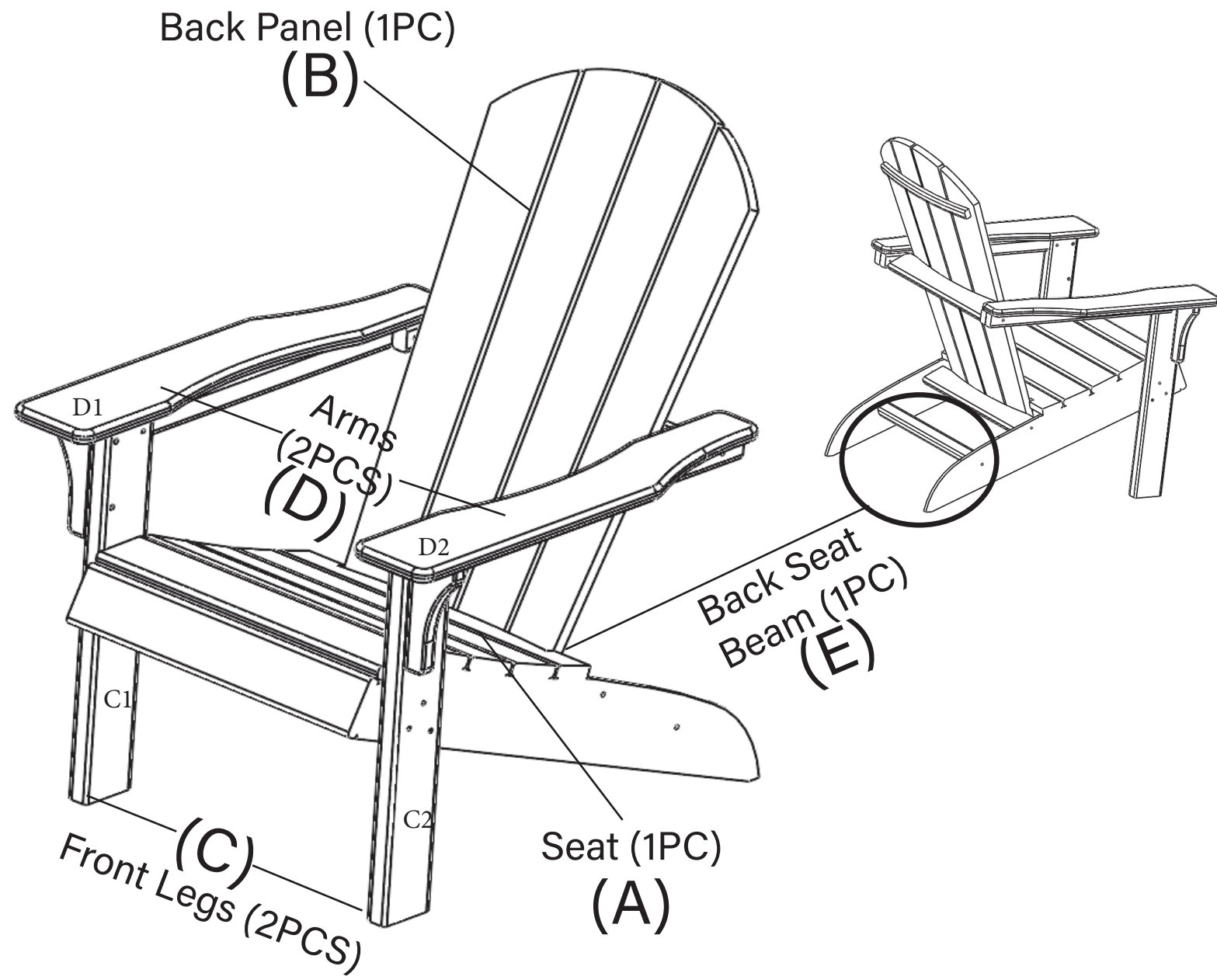

STEP-BY-STEP ASSEMBLY:

STEP 1: Attach Front Legs (C) to Seat (A) by inserting 3x 2.55" Bolts (H) on each side into the corresponding holes. Secure each bolt with a washer (G) and nut (F) as pictured.

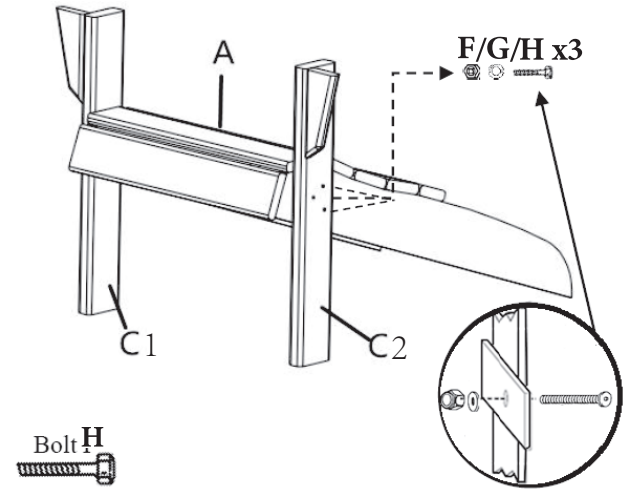

STEP 2: Attach the front part of the Arms (D) to the Front Legs (C) using 2.55" Bolts (H) and secure each with washer (G) and nut (F) as pictured on each side.

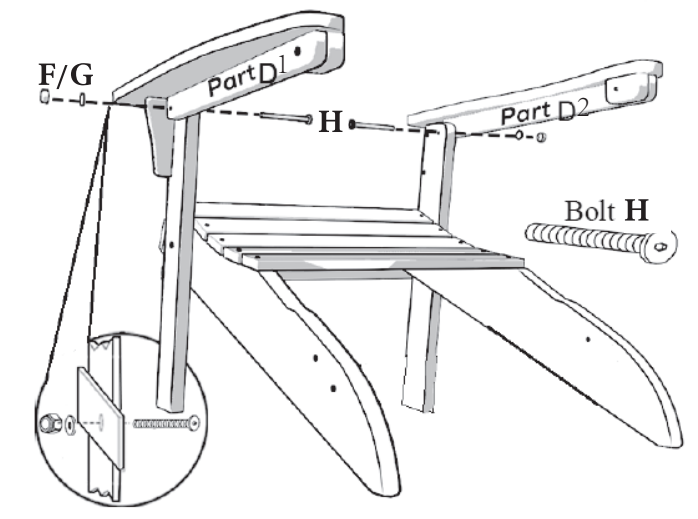

STEP 3: Attach the Back (B) to the Seat (A) using 2.4" Screws (J). Attach Back (B) to Arms (D) using 3.15" Screws (L) as pictured.

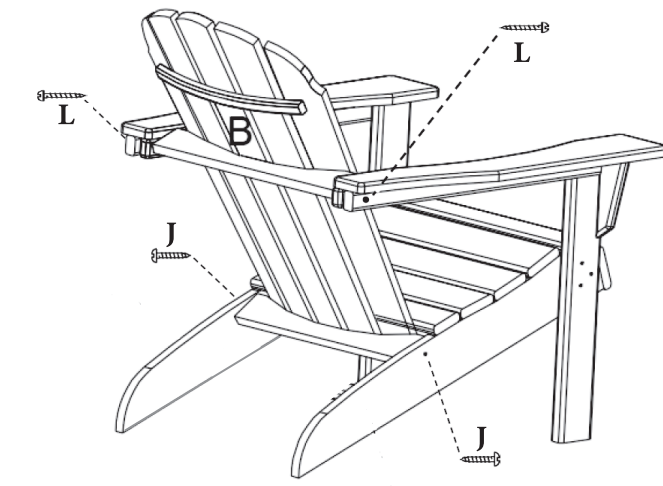

STEP 4: Attach Back Seat Beam (E) between the rear legs using 2.4" Screws (J) as pictured.

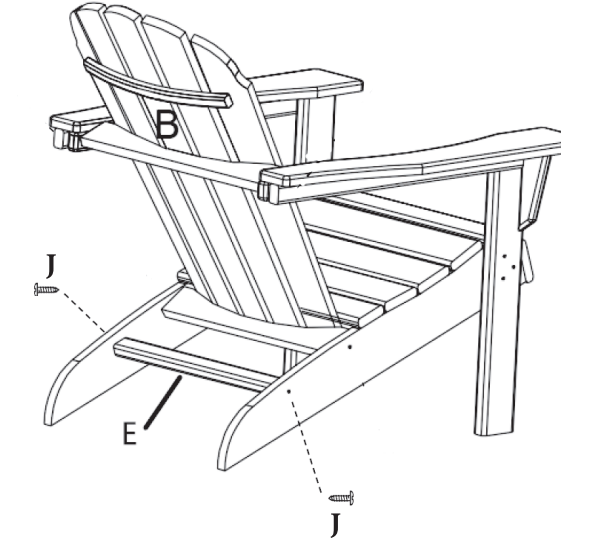

PART LIST:

A. Seat - 1Pc	B. Back - 1Pc	C. Front Legs - 2Pcs		D. Arms - 2Pcs		E. Back Seat Beam - 1Pc

HARDWARE LIST:

F. Lock Nut - 8Pcs 	G. Washer - 8Pcs 	H. Bolts 2.55" - 8Pcs 	J. Screws 2.4" - 4Pcs 	L. Screws 3.15" - 2Pcs
M. Allen Wrench - 1Pc 	N. Wrench - 1Pc 			

0 1 2 3 4 5 6 7 8 inch